

Top View

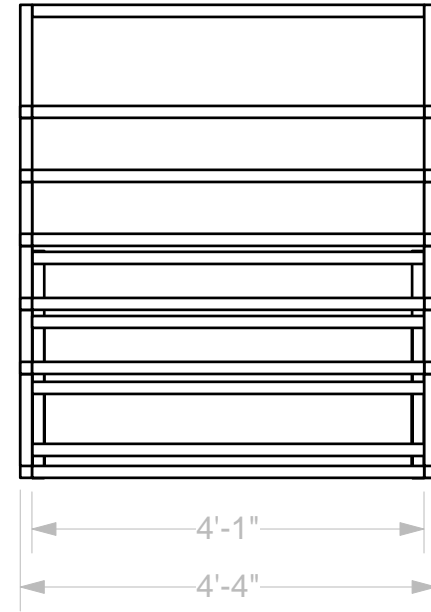

Front View



Top View

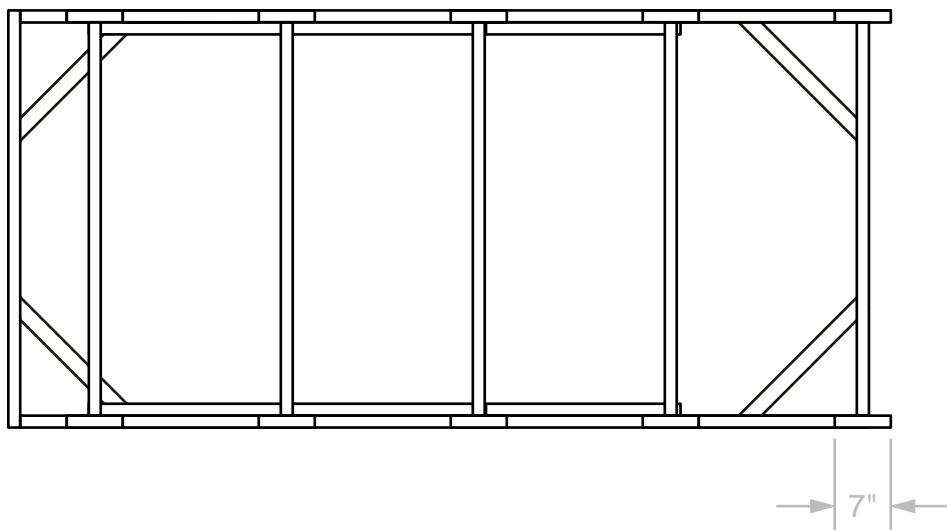

Bottom Frame

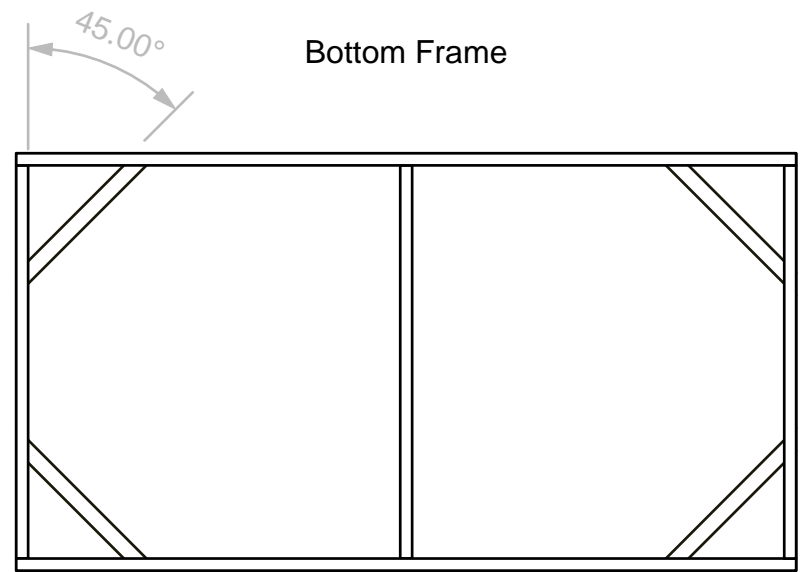

Notes-

1) To ensure square, set up a jig on a sheet of ply. Since the overall width of each section is 4'-4", just rotate the frame to fit the jig. You may use two sheets of ply if necessary.

2) I will supply you with the casters we will use. They will be centered on the 8 bottom diagonals and attached with U-bolts.

3) The side diagonals will be attached to the frame using the hex head bolts.

4) A separate drafting will be given with the size/position of 2x10s along with their attachment method.

- 1 1/2" Square Tube-
- 18 @ 4'-1"
- 20 @ 0'-7"
- 4 @ 8'-1 1/2"
- 4 @ 0'-11 1/2"
- 4 @ 1'-7 1/2"
- 4 @ 2'-3 1/2"
- 4 @ 2'-11 1/2"
- 4 @ 3'-7 1/2"
- 16 @ 1'-11 3/4"
- 4 @ 0'-7 1/2"
- 4 @ 1'-5" (w/98°)
- 4 @ 2'-0 3/4"
- 4 @ 2'-0 3/8"
- 4 @ 2'-1 3/8"
- 8 @ 1'-8 7/8" (w/ 45s on each side)

Risers

Marvel Theatre

Spelling Bee

Steel Layout

Dir.: Jessica Hillman

SM: Bethany Sortman

TD: Drew Van Genderen

ATD: Josh Jansen

Designer: Nick Menge

Date: September 7th, 2011  
 Scale: 1/2" = 1'-0"

Plate:  
 1 of 2